

COMFORT OCTAGONAL 180x80 cm

VitrA®

Size (cm) : 180x80
Height (cm) : 60
Weight (kg) : 25
Front Panel Weight (kg) : -
Side Panel Weight (kg) : -
Volume (lt) : 210
Available massage systems : Duo Soft
Aqua Maxi
Aqua Soft
Aqua Soft Easy

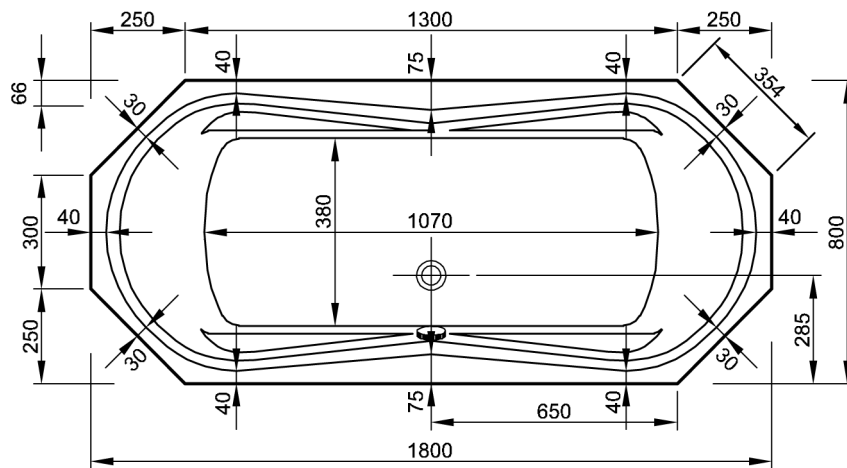

Plan

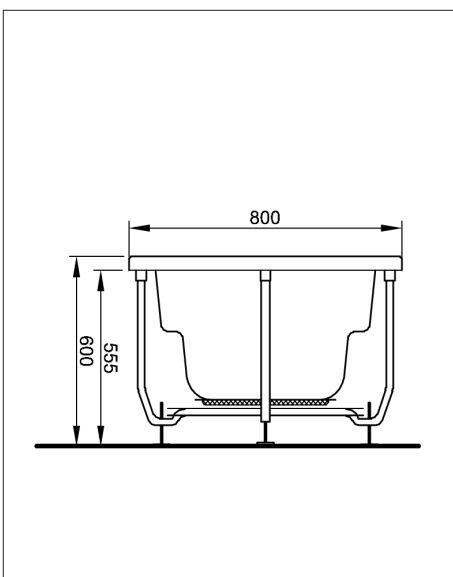

Side View

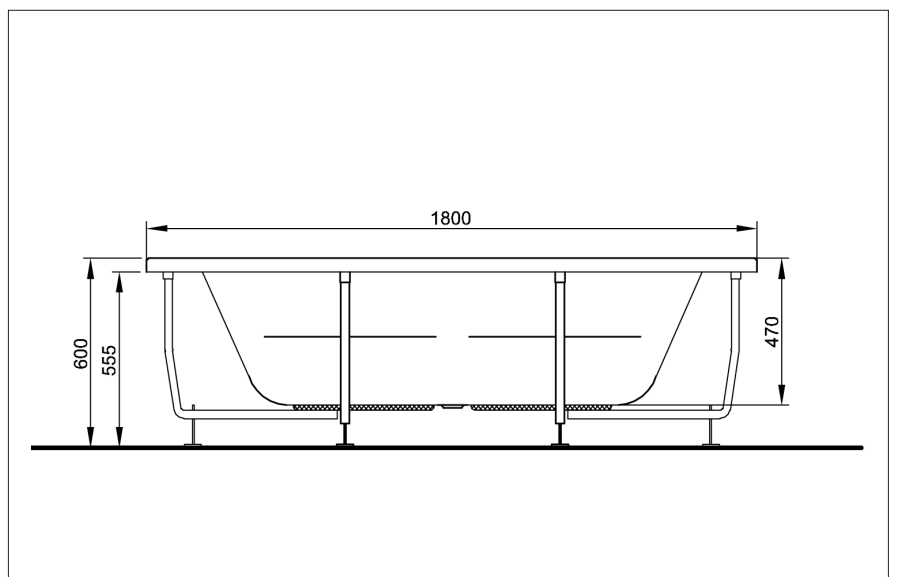

Front View

Points to Notice:

- An elbow and a waste connection hose of 50 mm. will be delivered with the product but an edge lath and other accessories are not included.
- The place where the product will be installed should be straight.
- The panels are not used with this product. The installation of this product must be done built-in
- For the products to be built-in, a motor airing and an access window should be left to the left side of the siphone (The direction can be determined by looking from the siphone side to the product) This window should be easily opened in case of defect.
- The electronical system is running with 220 volt (with earth connection). For its connection a 3x2,5 mm. cable should be used.
- The product should be protected with an appropriate ampere fuse (for Duo Maxi System 20 ampere, for Duo Soft System 16 ampere, for Aqua Maxi and Aqua Soft Systems 10 ampere) and the amper fuse should be closed when it is not used.
- The faucet applications should be from the points shown in the drawings below which are indicated with stickers on the product.
- The faucet should not be applied on the pump of the hydromassage bathtub.
- The spout should be min 17 cm. if the faucets are installed to the wall.
- Handgrip application for this product is not available.
- For the cleaning of the acrylic bathtub look at the User Manual.
- Waste connection fuse, wall hangers and user manual are delivered with the product.

Faucet Applications

ANY APPLICATION OF TABS ON THIS BATHTUB IS NOT POSSIBLE.

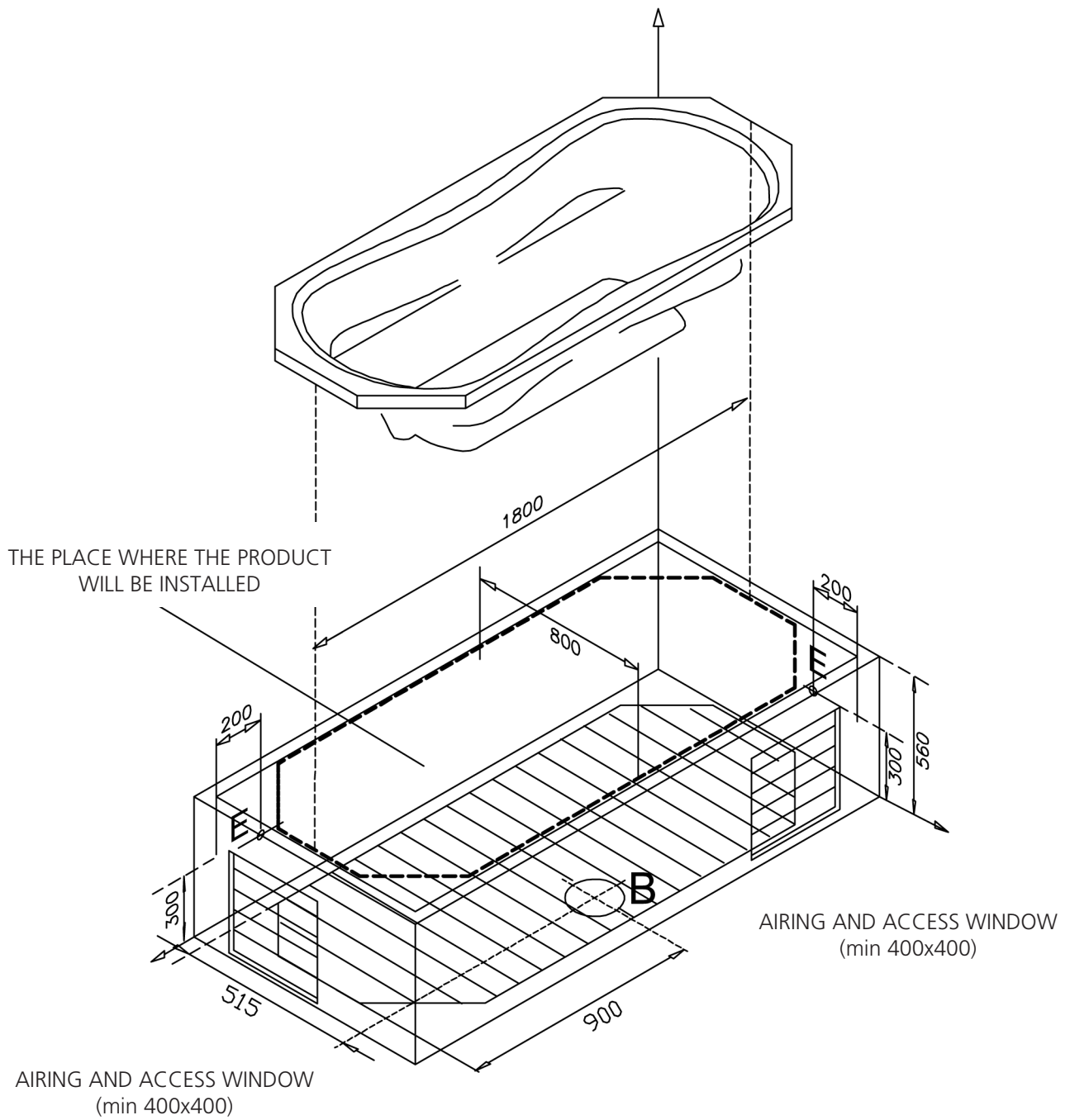

- ▣ : The area where the waste outlet (ø 50 mm) can be placed in.
- B : The area (ø 200 mm.) where the waste outlet should not be left.
- E : Measures for electrical connection of whirlpool tubs.

ATTENTION!

- Two control windows (airing) should be left
- One of the control windows of the hidromassage products should be left to access of the pump
- The size of the windows should be min 400 mm x400 mm

Massage Systems

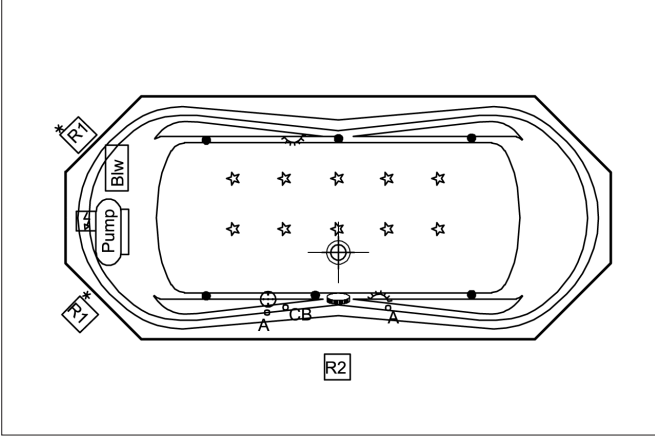

Duo Soft

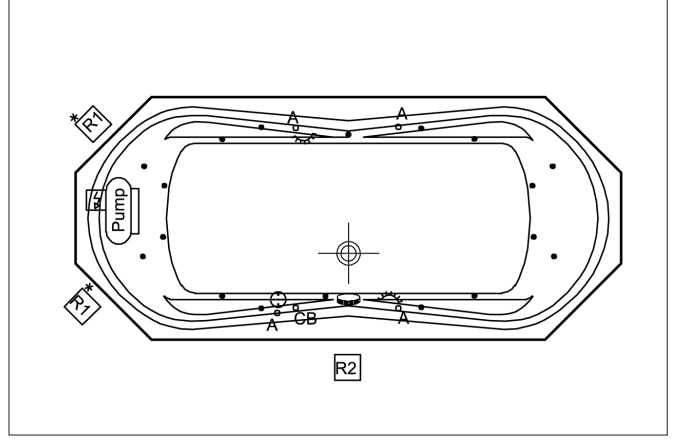

Aqua Maxi

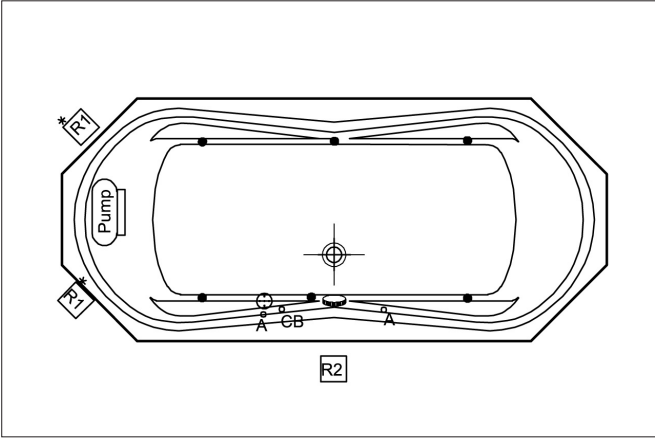

Aqua Soft

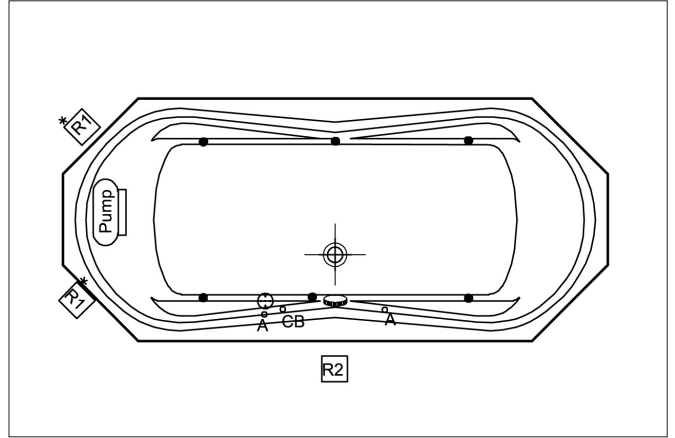

Aqua Soft Easy

Pump	Pump	Air Jets
Electronic Control Panel		Waste
Transformer		Water Jets
Blower		Micro Water Jets
Control Button		Underwater Light
Air Controller		Water Suction Filter
Push Button		

IMPORTANT!

- For the electrical connection of the hydromassage bathtubs, earth connection is necessary.
- The cable connection of the hydromassage bathtubs should be applied as shown in the Figure.
- Check whether the yellow-green earth cables bound with the metal parts placed under the hydromassage bathtubs are connected to all legs.

If the bathtub is used without panels, the following airing and access windows should be applied:

- R1** Access window (min. 400x400 mm.)
- R1*** Airing and access window (min. 400x400 mm.)
- R2** Access window (min. 400x400 mm.)
- R2*** Airing and access window (min. 250x250 mm.)